

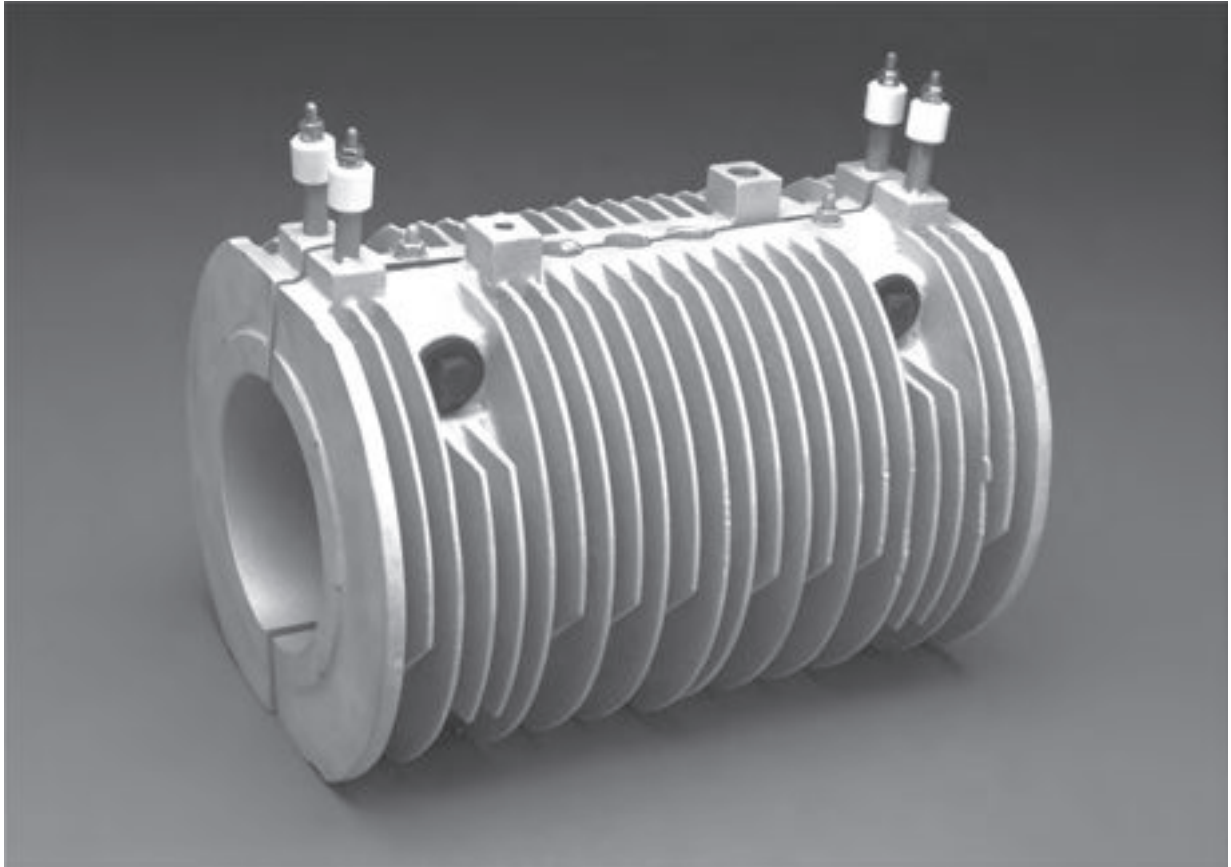

DURACAST™ AIR COOLED BARREL HEATERS



Air cooled barrel heaters utilize a cast fin pattern to maximize airflow over the body of the casting for cooling during the extrusion process. These heaters can be designed for individual shrouds with blowers or other forced air systems. Aluminum alloys are the primary materials used due to their excellent heat transfer characteristics. Bronze alloys can also be used with this

design for applications that require service temperatures in excess of 750°F.

Features:

- Manufactured with various fin patterns for maximum airflow distribution
- Available with low profile fins for space restricted designs
- Mounting to barrel can be bolt-on or strap-on design
- Engineered to fit any existing shroud assembly
- Wide variety of heavy duty electrical termination options



DURACAST™ AIR COOLED BARREL HEATERS

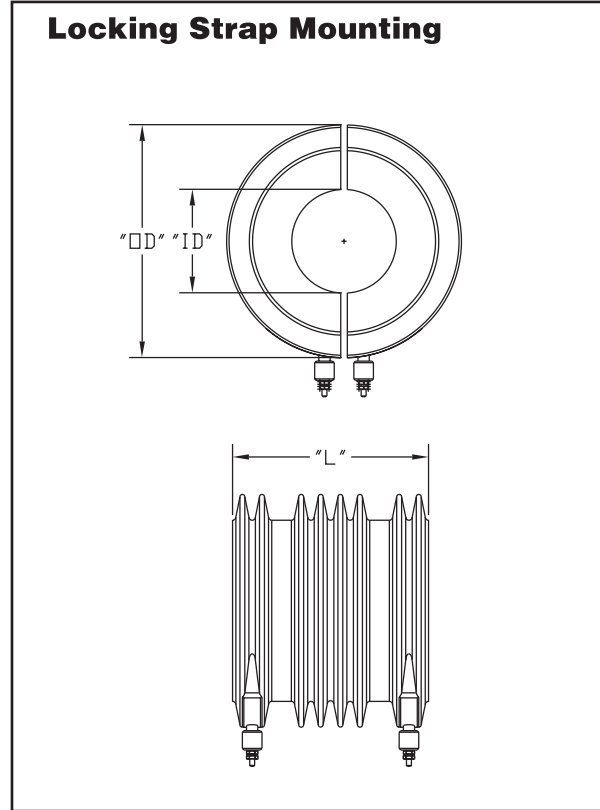
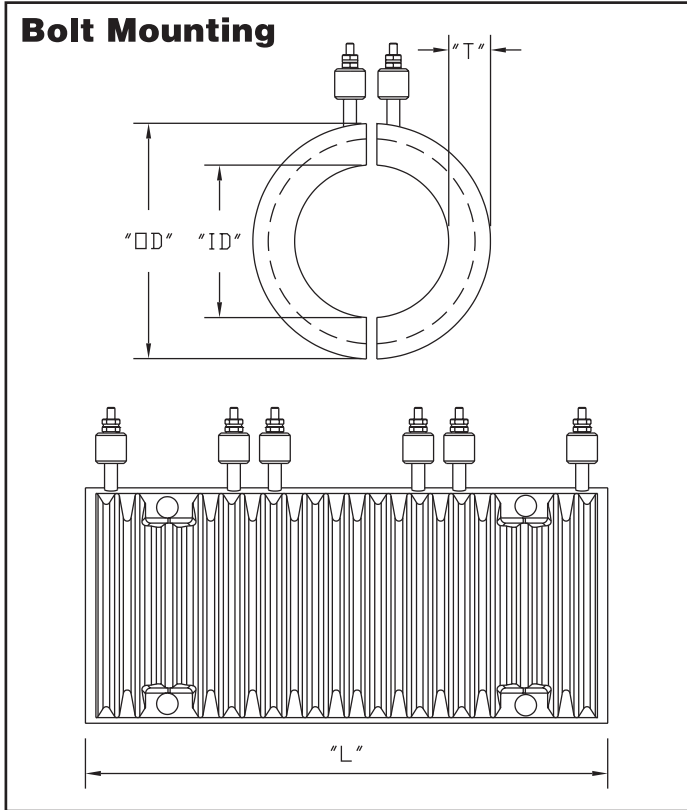

Ordering Information

Mounting Option:

Bolt

Locking Strap

Material:

Aluminum

Bronze

Inner Diameter ("D"):

Length ("L")

Wattage (Per Half):

Voltage (Per Half)

Number of Elements (Per Half):

Termination Type (See page at

end of section):

Hole on Notch Location:

Special Features:



ELECTRICAL TERMINATIONS

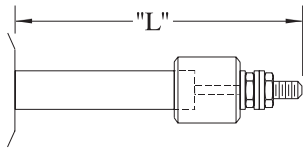

TYPE S

10-32 threaded screw terminal with ceramic insulator. Included nuts and washers. Type S standard for cast-in heaters. 6-32, 8-32 and metric sizes also available.

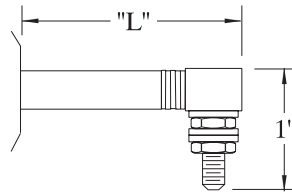

TYPE A

Right angle terminal block seated on mica washers with 10-32 threaded stud. Included nuts and washers.

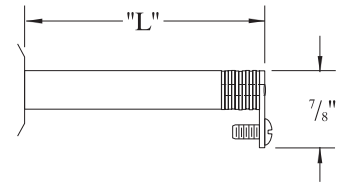

TYPE R

Screw lug terminal seated on mica washers and welded to pin. Includes 8-32 screw for wire connection.

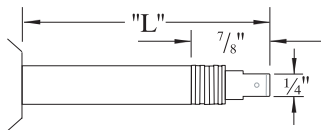

TYPE D

Quick-disconnect spade lug with 1/4" blade welded to pin. Other blade sizes available upon request.

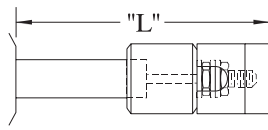

TYPE T

Ceramic insulator with ceramic top for insulation of electrical connections. Includes complete Type "S" termination with 10-32 threaded stud.

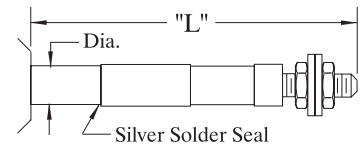

TYPE HS

Ceramic to metal hermetic seal is silver soldered directly to heating element for moisture-proof termination. 10-32 screw terminal includes nuts and washers.

Dia.	"L"	Thread
.430	1 1/8"	1/4-28
.315	1 3/8"	10-32
.250	1 5/8"	8-32

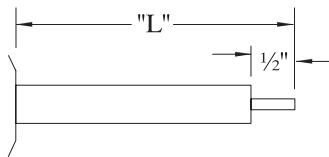

TYPE P

Plain pin for field attachment of termination. Pin Length is 1/2" standard.

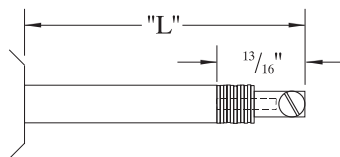

TYPE L

Terminal lug with 10-32 screw is welded directly to heater pin. Can be oriented straight or at a right angle.

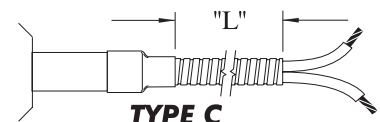

TYPE C

Flexible armor cable for abrasion resistance with high temperature leadwire attached to heating element. Specify "L" dimension when ordering.

Special Termination Design and Element Seals Are Also Available.

COOLING TUBE TERMINATIONS

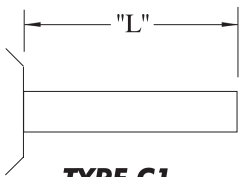

TYPE C1

Plain cooling tube cut to standard 3" length extending from heater. Specify longer length if required.

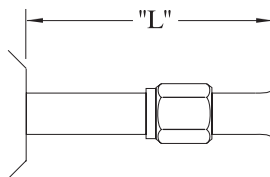

TYPE C2

37° Flare nut fitting allows for cooling tube connection to compression fitting.

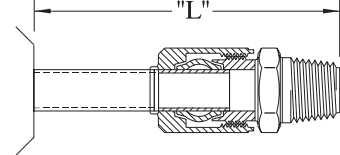

TYPE C3

Compression fitting mounted directly to cooling tube provides seal for high pressure hook up. Available in standard 3/8" and 1/2" NPT.

3/8 Dia #55-0010 1/2 Dia #55-0011

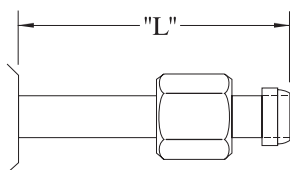

TYPE C4

Brazed seal with locknut provides an effective seal for high pressure applications. Mating fittings available upon request.

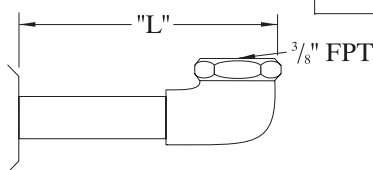

TYPE C5

Brazed angle fitting mounted directly to cooling tube with right angle 3/8 FPT as standard. Specify "L" dimensions for clearance.

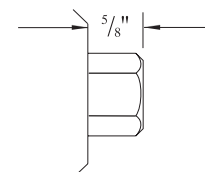

TYPE C6

Cast-in fitting with standard 3/8 FPT for quick installation of cooling lines with no additional fittings.



PROTECTIVE HOUSINGS

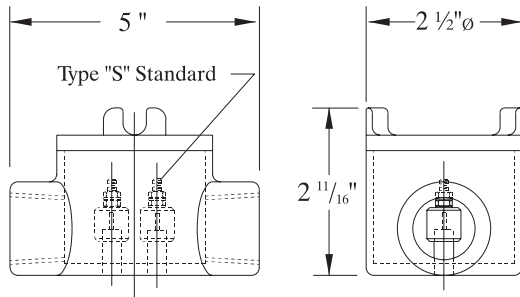

Type B1

Explosion proof cast iron housing with 1/2" NPT double hub. Single phase design shown. Larger housing for 3 phase design also available.

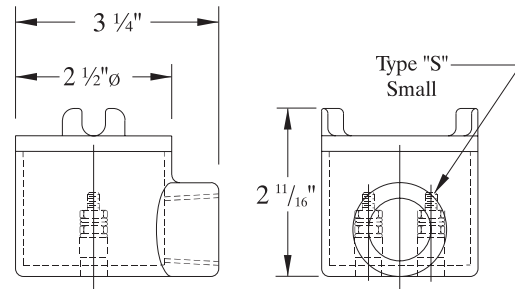

Type B2

Explosion proof cast iron housing with 1/2" NPT single hub. Single phase design shown. Larger housing for 3 phase design also available.

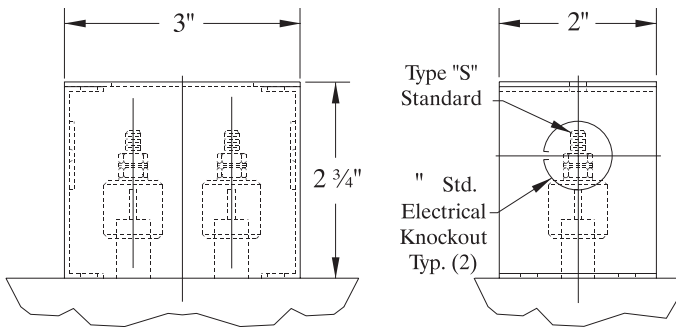

Type B3

Standard size stainless steel sheet metal box with (2) 1/2" electrical knockouts. Other sizes and types available.

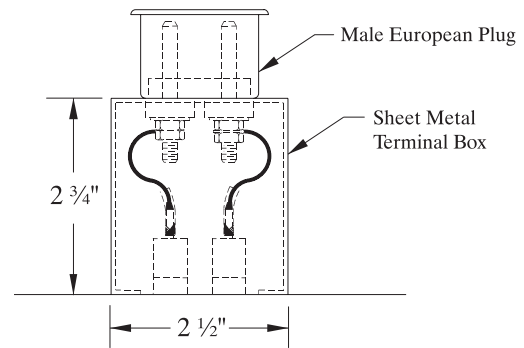

Type B4

Stainless steel terminal enclosure with male ERGE plug mounted on top. Mating connections available upon request.

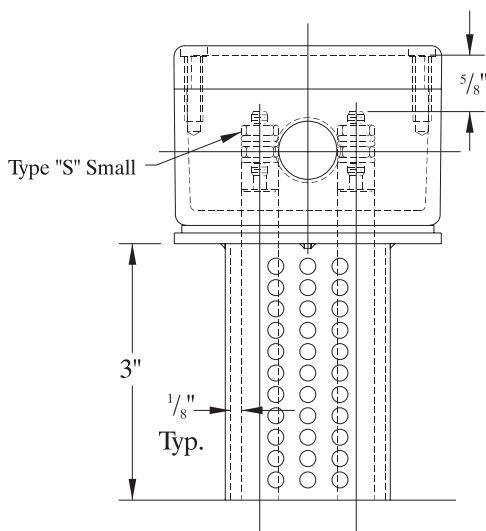

Type B5

Die cast aluminum enclosure with 1/2" or 3/4" threaded electrical connections mounted to vented cooling tower. Other sizes and types available for single and 3 phase designs.

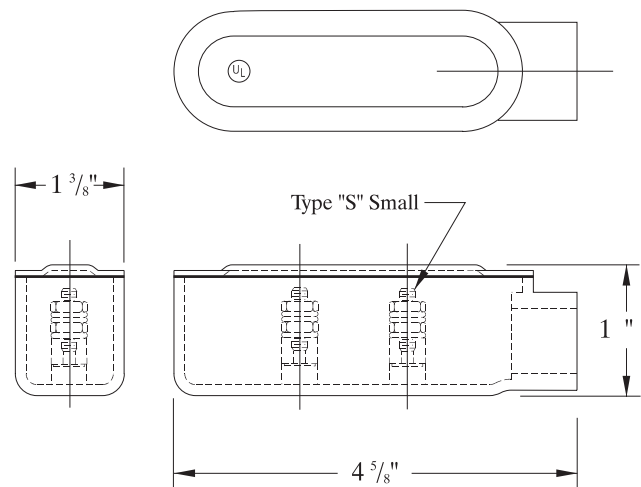

Type B6

Explosion proof box with 1/2" NPT single hub, designed for low profile applications. Single phase only. Different hub configurations are available.



DURACAST™ HEATER SPECIFICATIONS

Cast Materials	Max. Operating Temperature
Aluminum 443	800°F (427°C)
Aluminum 319/356	700°F (371°C)
Bronze/Copper alloys	1400°F (769°C)
Iron	900°F (482°C)

If required, other cast materials are available

Cast Processes

Durocast™ perm-mold system uses steel permanent molds. No bake sand system for special castings and short production runs.

Machine Finish

CNC machining is performed for tight tolerances and complex configurations. Milled finishes are provided per specification. Belt sanding, lapping and polishing available to meet application specifications.

Standard Machine Finish Range: 64 to 125 rms.

Fine Finish Per Specifications: 8 to 32 rms.

Standard Flatness: Belt Sanded: .015

Milled: ±.005

Lapped: .001

Holes, Cutouts, Thermowells

Mounting or clearance holes, cutouts and thermowells, for inserting temperature measurement probes, cast-in or machined per your specifications.

Inserts

Threaded studs, precision component parts, bushings and special design parts cast accurately in place.

Electrical

Resistance tolerance NEMA standard +10% -5%.

Voltages:

Element diameter	.200	.260	.315	.430	.475
Maximum volts	240	240	277	600	600

(Three phase available on large heaters.)

Maximum watt densities depends on size and application. Consult a Durex Engineer.

UL Component Recognition

DA series cast-in heaters are recognized per file E110394.

Inspection/Testing

- Electrical per UL 499 and UL 1030, Canadian
- Standard C22.2 No. 72
- Dimensional per specifications using
- Coordinate Measure Machine
- Quality standard per MIL-Q_9858A



CAST-IN HEATER SPECIAL SERVICES

Radiograph (X-ray):

Confirmation of internal element configuration and casting soundness available through X-ray.

Plating/Coating:

Electroless nickel plating, anodize, Telfon[®] coatings and special blasted surfaces are available per customer specification.

Pressure Testing:

High pressure leakage testing is done in-house per application requirements.

Heat Treating:

Stress relieving and aging through heat treating available as required.

CMM Inspection:

Coordinate Measuring Machine used for precision quality control of tight tolerance machining requirements.

Helium Leak:

Detect microleakage from casting body.

Temperature Uniformity:

Confirm heat uniformity across the finished surface.

Class 1000 Clean Room:

Clean room assembly and packaging per class 1000 standards.

Solidworks 3D Modeling:

Engineering software provides 3D models of proposed or existing product designs.

Custom Packaging:

Customer specific packaging for delicate surfaces, large multi-product shipments, or long term storage.

Life Cycle Testing:

Life cycle test chamber for long term testing of uniformity and performance characteristics.

Material Certifications:

Precise records and certifications on materials which require traceability to specific standards.

Sensor Calibration:

NIST traceable calibration lab for calibration and certification of any temperature sensor requirements.

FEA Analysis:

Preview of proposed design constructions using FEA analysis.



INSTALLATION AND MAINTENANCE GUIDELINES FOR CAST-IN HEATERS

1. Always ensure that cast-in heaters are properly mounted to the application to avoid warping of flat heaters or "walking" of barrel heaters. After the initial start-up, retighten the heater mounting system to assure complete surface contact. Periodically check bolts or straps and tighten as required maintenance.
2. Tighten all liquid cool connections securely to avoid rupture from internal steam pressures. Cast-in C6 fittings or brazed connections are the most reliable. Properly maintain these connections to avoid leaks that will destroy the heater. Do not operate heating and cooling simultaneously to avoid thermal shock of the cooling tubes.
3. It is recommended that water used for liquid cooling applications be treated to avoid corrosion and hard water deposits that will clog the cooling tubes over time.
4. Install proper temperature control prior to operation of the heaters to ensure protection from over-temp situations which may damage the heater or equipment. Periodically changing temperature sensors is good preventive maintenance.
5. Electrical terminals must be properly insulated and made tightly to ensure safe operation. All heater installations must be properly grounded. All electrical terminations must be made per applicable Electrical Safety Codes and O.S.H.A. regulations.
6. Do not operate the heaters outside of the rated voltage and temperature of the design. This will cause the heaters to fail.
7. ALWAYS disconnect the electrical power to heaters prior to service.

ELECTRICAL DATA

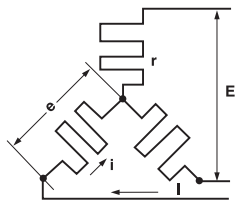

WYE OR STAR CONNECTION

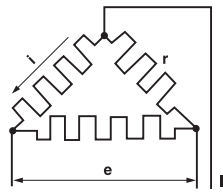

DELTA CONNECTION

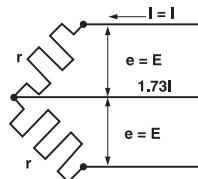

3-PHASE OPEN DELTA

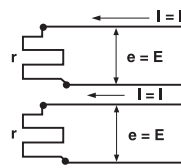

2-PHASE 4 WIRE

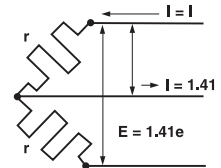

2-PHASE 3 WIRE

The energy put out by a heating unit is measured in watts. The power factor is always unity.

Single phase, $W = I^2 R = EI$

Three Phase Delta, $W = 3EI = 1.73 EI$

Three Phase Wye, $W = 3ei = 1.73 EI$

Two Phase 4 Wire, $W = 2I^2R = 2 EI$

Two Phase, 3 Wire, $W = 2I^2R = 2 EI$

(Voltage between outside wires = 1.41e)

$$\text{Phase Amps} = I = \frac{W}{E \times \text{PF}}$$

$$\text{A.C., 3 Phase Amps} = I = \frac{W}{1.73 E \times \text{PF}}$$

$$\text{A.C., 2 Phase 3 Wire: Middle Wire Amps} = \text{Amps in outside Wire} \times 1.41$$

W = Power, Watts

E = E.M.F. Volts

I = Current, Amperes

R = Resistance, Ohms

PF = Power Factor

$$\text{Amps} = I = \frac{W}{E} = \frac{E}{R}$$

OHMS LAW

