

Thank you for purchasing the RKC product. In order to achieve maximum performance and ensure proper operation of your new instrument, carefully read all the instructions in this manual. Please place this manual in a convenient location for easy reference.

**WARNING**

- An external protection device must be installed if failure of this instrument could result in damage to the instrument, equipment or injury to personnel.
- All wiring must be completed before power is turned on to prevent electric shock, fire or damage to instrument and equipment.
- This instrument must be used in accordance with the specifications to prevent fire or damage to instrument and equipment.
- This instrument is not intended for use in locations subject to flammable or explosive gases.
- Do not touch high-voltage connections such as power supply terminals, etc. to avoid electric shock.
- RKC is not responsible if this instrument is repaired, modified or disassembled by other than factory-approved personnel. Malfunction can occur and warranty is void under these conditions.

CAUTION

- This is a Class A instrument. In a domestic environment, this instrument may cause radio interference, in which case the user may be required to take adequate measures.
- This instrument is protected from electric shock by reinforced insulation. Provide reinforced insulation between the wire for the input signal and the wires for instrument power supply, source of power and loads.
- Be sure to provide an appropriate surge control circuit respectively for the following:
 - If input/output or signal lines within the building are longer than 30 meters.
 - If input/output or signal lines leave the building, regardless the length.
- This instrument is designed for installation in an enclosed instrumentation panel. All high-voltage connections such as power supply terminals must be enclosed in the instrumentation panel to avoid electric shock by operating personnel.
- All precautions described in this manual should be taken to avoid damage to the instrument or equipment.
- All wiring must be in accordance with local codes and regulations.
- All wiring must be completed before power is turned on to prevent electric shock, instrument failure, or incorrect action. The power must be turned off before repairing work for input break and output failure including replacement of sensor, contactor or SSR, and all wiring must be completed before power is turned on again.
- To prevent instrument damage of failure, protect the power line and the input/output lines from high currents with a protection device such as fuse, circuit breaker, etc.
- Prevent metal fragments or lead wire scraps from falling inside instrument case to avoid electric shock, fire or malfunction.
- Tighten each terminal screw to the specified torque found in the manual to avoid electric shock, fire or malfunction.
- For proper operation of this instrument, provide adequate ventilation for heat dispensation.
- Do not connect wires to unused terminals as this will interfere with proper operation of the instrument.
- Turn off the power supply before cleaning the instrument.
- Do not use a volatile solvent such as paint thinner to clean the instrument. Deformation or discoloration will occur. Use a soft, dry cloth to remove stains from the instrument.
- To avoid damage to instrument display, do not rub with an abrasive material or push front panel with a hard object.
- Do not connect modular connectors to telephone line.

NOTICE

- This manual assumes that the reader has a fundamental knowledge of the principles of electricity, process control, computer technology and communications.
- The figures, diagrams and numeric values used in this manual are only for purpose of illustration.
- RKC is not responsible for any damage or injury that is caused as a result of using this instrument, instrument failure or indirect damage.
- Periodic maintenance is required for safe and proper operation of this instrument. Some components have a limited service life, or characteristics that change over time.
- Every effort has been made to ensure accuracy of all information contained herein. RKC makes no warranty expressed or implied, with respect to the accuracy of the information. The information in this manual is subject to change without prior notice.
- No portion of this document may be reprinted, modified, copied, transmitted, digitized, stored, processed or retrieved through any mechanical, electronic, optical or other means without prior written approval from RKC.

1. PRODUCT CHECK

SA100L□□□ - □□ - □ * □□ - □□/□□/□
 (1) (2)(3) (4) (5)(6) (7)(8) (9)

(1) Input type/Range code

See 11. INPUT CODE TABLES. (P. 10)

(2) Output 1 (Limit output or Transmission output)

M: Relay contact output 7: Current output (0 to 20 mA DC)
 8: Current output (4 to 20 mA DC)

(3) Output 2 (Limit output or Alarm output)

N: No output M: Relay contact output
 When the output 1 is "7" or "8," output 2 is fixed to "M."

(4) Power supply voltage

3: 24 V AC/DC 4: 100 to 240 V AC

(5) Alarm 1 and (6) Alarm 2

N: No alarm G: Deviation high/low alarm ¹
 A: Deviation high alarm H: Process high alarm
 B: Deviation low alarm J: Process low alarm
 C: Deviation high/low alarm K: Process high alarm ¹
 D: Band alarm L: Process low alarm ¹
 E: Deviation high alarm ¹ V: SV high alarm
 F: Deviation low alarm ¹ W: SV low alarm

(7) Option function

N: No function D: Contact input
 5: RS-485 (RKC communication) 6: RS-485 (Modbus)

(8) Waterproof/dustproof

N: No waterproof/dustproof 1: Waterproof/dustproof

(9) Output assignment code

No symbol: Standard output

When the OUT1 is relay contact output;

OUT1: Limit output ²
 OUT2: OR output of alarm 1 and alarm 2 ³

or

When the OUT1 is current output;

OUT1: Transmission output
 OUT2: Limit output ²

02: OUT1: Limit output ², OUT2: AND output of alarm 1 and alarm 2 ³

03: OUT1: Limit output ², OUT2: Alarm 1 output ³

04: OUT1: Limit output ², OUT2: OR output of alarm 1 and alarm 2 ²

05: OUT1: Limit output ², OUT2: AND output of alarm 1 and alarm 2 ²

06: OUT1: Limit output ², OUT2: Alarm 1 output ²

07: OUT1: Limit output ², OUT2: OFF

08: OUT1: Limit output ³, OUT2: OR output of alarm 1 and alarm 2 ³

09: OUT1: Limit output ³, OUT2: AND output of alarm 1 and alarm 2 ³

10: OUT1: Limit output ³, OUT2: Alarm 1 output ³

11: OUT1: Limit output ³, OUT2: OR output of alarm 1 and alarm 2 ²

12: OUT1: Limit output ³, OUT2: AND output of alarm 1 and alarm 2 ²

13: OUT1: Limit output ³, OUT2: Alarm 1 output ²

14: OUT1: Limit output ³, OUT2: OFF

16: OUT1: Transmission output, OUT2: Limit output ³

¹ With hold action

² De-energized

³ Energized

2. MOUNTING**WARNING**

To prevent electric shock or instrument failure, always turn off the power before mounting or removing the instrument.

2.1 Mounting Cautions

(1) This instrument is intended to be used under the following environmental conditions. (IEC61010-1)
 [OVERVOLTAGE CATEGORY II, POLLUTION DEGREE 2]

(2) Use this instrument within the following ambient temperature and ambient humidity.

- Allowable ambient temperature: 0 to 50 °C
- Allowable ambient humidity: 45 to 85 %RH
 (Absolute humidity: MAX. W. C 29 g/m³ dry air at 101.3 kPa)

(3) Avoid the following when selecting the mounting location.

- Rapid changes in ambient temperature which may cause condensation.
- Corrosive or inflammable gases.
- Direct vibration or shock to the mainframe.
- Water, oil, chemicals, vapor or steam splashes.

Continued on the next page.

- Excessive dust, salt or iron particles.
- Excessive induction noise, static electricity, magnetic fields or noise.
- Direct air flow from an air conditioner.
- Exposure to direct sunlight.
- Excessive heat accumulation.

(4) Mounting consideration

- Install the instrument 200 mm away from the main power line.
- If the ambient temperature rises above 50 °C, cool this instrument with a forced air fan, cooler, or the like. However, do not allow cooled air to blow this instrument directly.

2.2 Dimensions

External dimension

(Unit: mm)

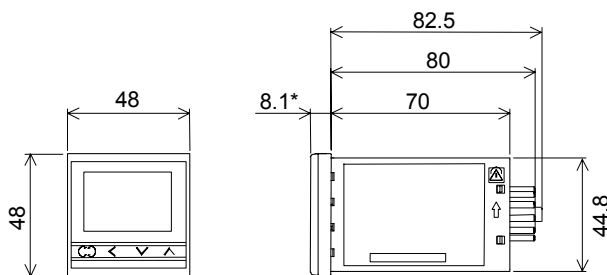
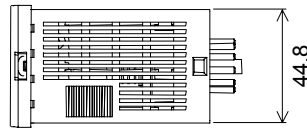

* Waterproof/dustproof (IP66) type: 9.1 mm

Panel cutout

(Unit: mm)

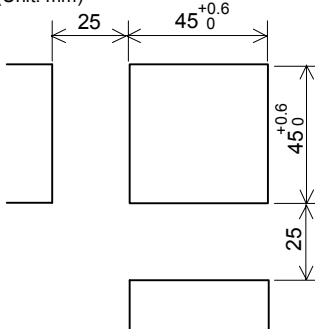

Installation Conditions:
The display can not be seen from the outside of the visual field range. The visual field range of SA100L is 40° to the upper side, and 30° to the lower side from the center of the display vertically.

For mounting of the SA100L, panel thickness must be between 1 to 10 mm.

2.3 Mounting Procedures

DIN rail mounting

1. Mounting the socket to the DIN rail. (Fig. 1)
2. Wiring to the socket. Then, mounting the instrument to the socket.
3. Secure the instrument by locking it with the hooks at the top and bottom of the socket. (Fig. 2)

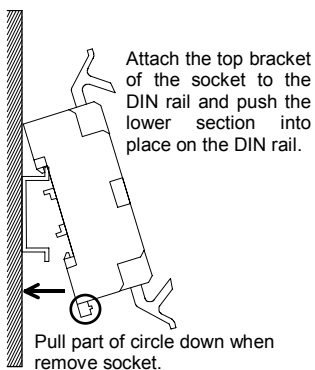

Fig. 1

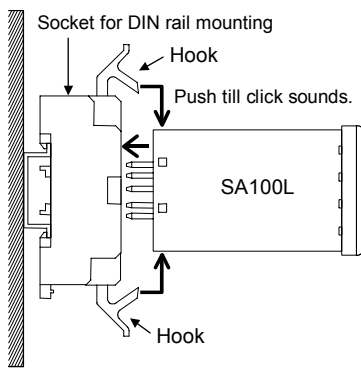
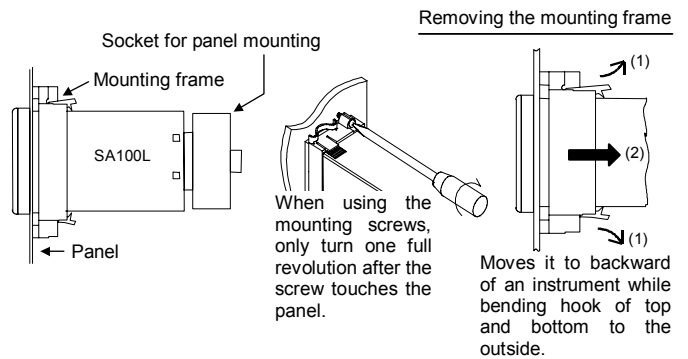

Fig. 2

Please prepare socket with a customer.
Recommended socket for DIN rail mounting:
ATC180041 (Matsushita Denko product)

Panel mounting

1. Prepare the panel cutout as specified in 2.2 Dimensions.
2. Insert the instrument through the panel cutout.
3. Insert the mounting frame into the mounting from the rear of the instrument.
4. Push the mounting frame forward until the frame is firmly secured to the panel.
5. Mounting the socket to the instrument.



Please prepare mounting frame and socket with a customer.
Mounting frame type:
KCA100-59 (RKC product, Sold separately)
Recommended socket for panel mounting:
AT78051 (Matsushita Denko product)

The waterproof/dustproof option on the front of the instrument conforms to **IP66** when mounted on the panel. For effective waterproof/dustproof, the gasket must be securely placed between instrument and panel without any gap. If gasket is damaged, please contact RKC sales office or the agent.

3. WIRING



WARNING

To prevent electric shock or instrument failure, do not turn on the power until all the wiring is completed.

3.1 Wiring Cautions

- For thermocouple input, use the appropriate compensation wire.
- For RTD input, use low resistance lead wire with no difference in resistance between the three lead wires.
- To avoid noise induction, keep input signal wire away from instrument power line, load lines and power lines of other electric equipment.
- If there is electrical noise in the vicinity of the instrument that could affect operation, use a noise filter.
 - Shorten the distance between the twisted power supply wire pitches to achieve the most effective noise reduction.
 - Always install the noise filter on a grounded panel. Minimize the wiring distance between the noise filter output and the instrument power supply terminals to achieve the most effective noise reduction.
 - Do not connect fuses or switches to the noise filter output wiring as this will reduce the effectiveness of the noise filter.
- About four seconds are required as preparation time for contact output every time the instrument is turned on. Use a delay relay when the output line is used for an external interlock circuit.
- Power supply wiring must be twisted and have a low voltage drop.
- For an instrument with 24 V power supply, supply power from a SELV circuit.
- This instrument is not furnished with a power supply switch or fuse. Therefore, if a fuse or power supply switch is required, install close to the instrument.
 - Recommended fuse rating: Rated voltage 250 V, Rated current 1 A
 - Fuse type: Time-lag fuse
- For the current input specification, a resistor of 250 Ω (±0.02 % ±10 ppm, 0.25 W or more) must be connected between the input terminals. If this resistor is installed, close vertical mounting is not possible. This resistor must be provided by the customer.
- The input and output terminals for the voltage pulse output are not isolated. Always use an isolating type SSR. If the grounded type sensor is used, do not ground output wiring. Do not connect any output wires to the terminals with any other output wires.

3.2 Terminal configuration

■ Socket for DIN rail mounting (ATC180041)

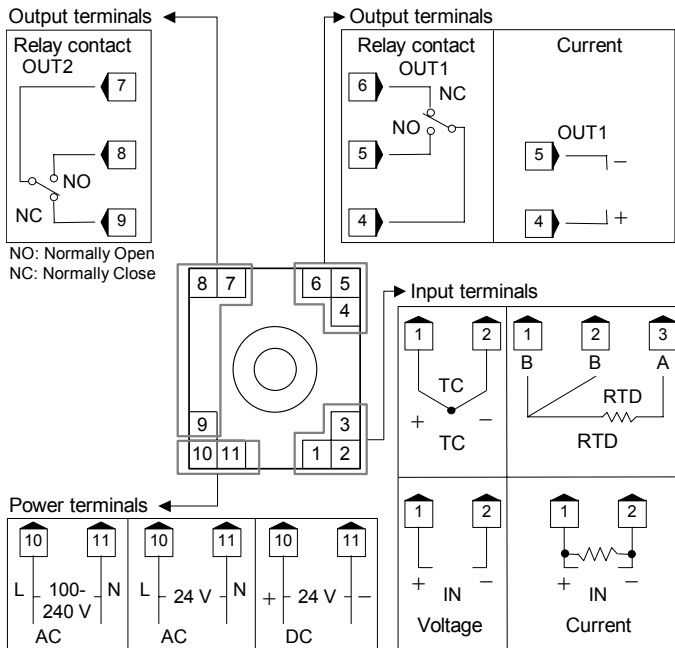

■ Socket for panel mounting (AT78051)

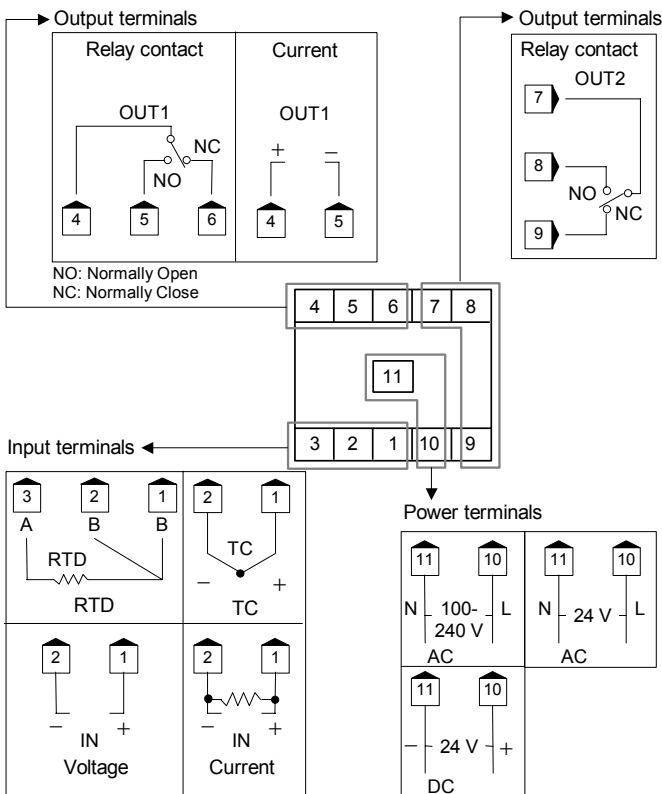

■ Option

Communication function and contact input are optional. Connect connector to bottom of instrument. A connector and connector cable for connecting the input block is necessary to be prepared by the customer.

Housing: XHP-3 (J.S.T. Mfg. Co., Ltd. product)
Recommended cable size: AWG30 to 22

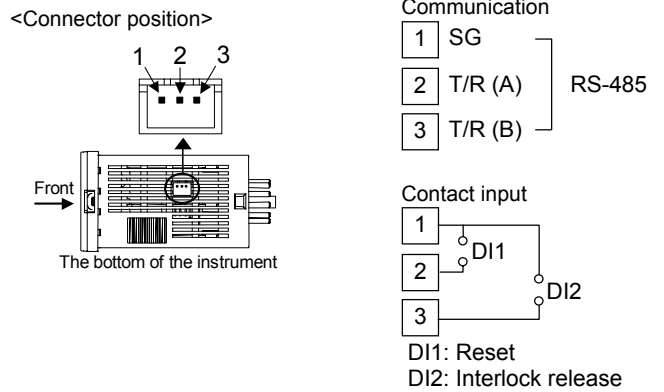

4. PARTS DESCRIPTION

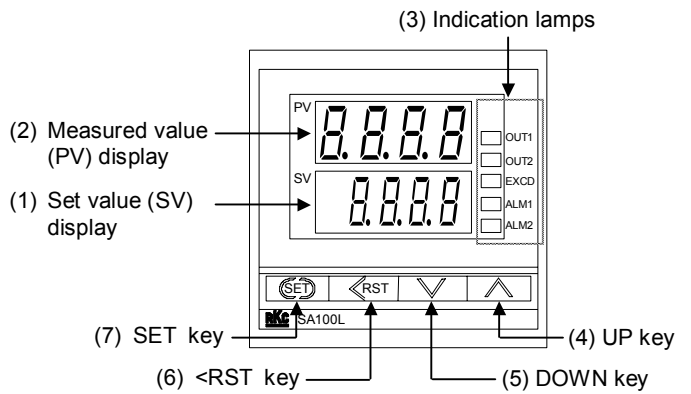

(1) Set value (SV) display [Red]

Displays limit set value (SV) or various parameter set values.

(2) Measured value (PV) display [Green]

Displays PV or various parameter symbols.

(3) Indication lamps

Output lamps (OUT1, OUT2) [Green]

OUT1: Lights when output 1 is turned on.
OUT2: Lights when output 2 is turned on.

EXCD lamp [Red]

Lights while a measured value (PV) exceeds the limit set value (SV).

Alarm lamps (ALM1, ALM2) [Red]

ALM1: Lights when alarm 1 is turned on.
ALM2: Lights when alarm 2 is turned on.

(4) UP key

Increase numerals.

(5) DOWN key

Decrease numerals.

(6) Shift & Reset key (<: Shift key, RST: Reset key)

Shift digits when settings are changed.
The limit output is released (reset).

(7) SET key

Used for parameter calling up and set value registration.

To avoid damage to the instrument, never use a sharp object to press keys.

5. SETTING

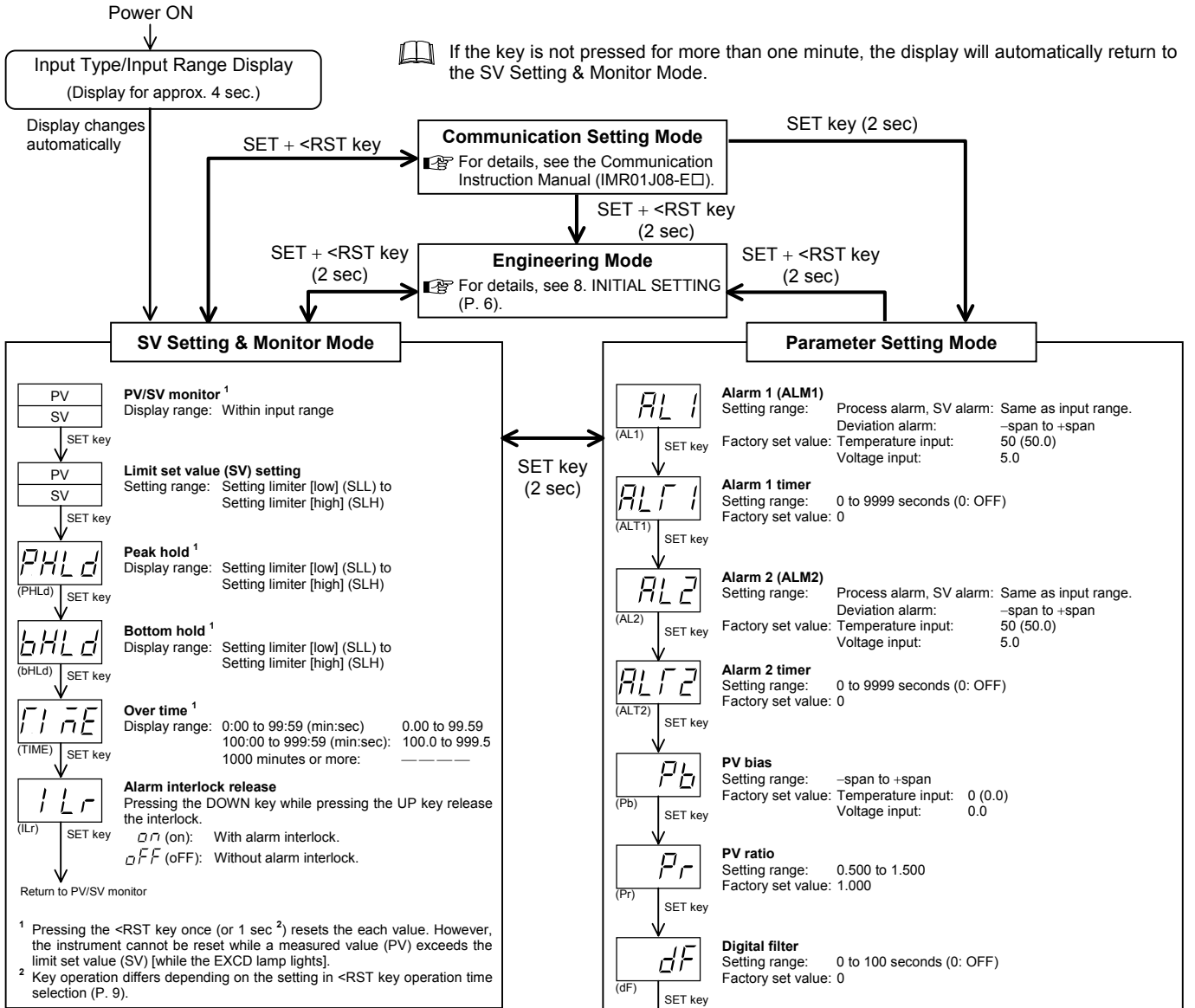

Input type and input range display

When the instrument is powered on, it immediately confirms the input type and input range.

[Example] Input type: Thermocouple K, Input range: 0 to 1372 °C

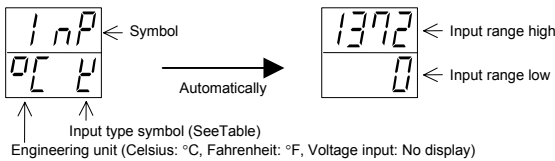

Input Type Symbol Table

Symbol	P	V	r	S	b	E	f	n	P	U	L	U	P	P	V	
Input type	Thermocouple (TC)										RTD		Voltage			
	K	J	R	S	B	E	T	N	PL II	W5Re/W26Re	U	L	JPt 100	Pt 100		

SV Setting & Monitor Mode

When the power is turned on, the controller goes to this mode after self-diagnostics. To go to the next parameter, press SET key. In this mode, the following operations are possible.

- Set the limit set value (SV).
The blinking digit on the SV display indicates which digit can be set.
Setting range: Within input range
Factory set value: Temperature input: 0 (0.0) °C [°F]
Voltage input: 0.0 %
- Monitor the measured value (PV), limit set value (SV), peak hold value, bottom hold value and time exceeding the time limit.

Setting	Lock level
0000	SV and all parameter can be set.
0001	Only SV and alarms can be set.
0010	Only setting items other than alarms can be set.
0100	Only setting items other than SV can be set.
0011	Only SV can be set.
0101	Only alarms can be set.
0110	Only setting items other than SV and alarms can be set.
0111	SV and all parameter cannot be set.

■ Changing Parameter Settings

Procedures to change parameter settings are shown below.

To store a new value for the parameter, always press the SET key. The display changes to the next parameter and the new value will be stored.

- A new value will not be stored without pressing SET key after the new value is displayed on the display.
- After a new value has been displayed by using the UP and DOWN keys, the SET key must be pressed within one minute, or the new value is not stored and the display will return to the SV setting & Monitor mode.



When the set data is locked, the digits on the SV display are brightly lit and the set value cannot be changed.

● Change the limit set value (SV)

Change the limit set value (SV) from 0 °C to 200 °C

1. Select the limit set value (SV) setting

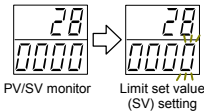

Press the SET key at SV Setting & Monitor Mode until limit set value (SV) setting screen is displayed.

2. Shift the blinking digit

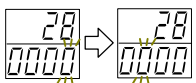

Press the <RST key to blink the hundreds digit. The blinking digit indicates which digit can be set.

3. Change the limit set value

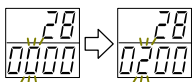

Press the UP key to change the number to 2.

4. Store the limit set value

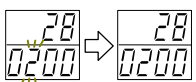

Press the SET key to store the new set value. The display returns to the PV/SV monitor screen.

● Change parameters other than the limit set value (SV)

The changing procedures are the same as those of example 2. to 4. in the above "● Change the limit set value (SV)." Pressing the SET key after the setting end shifts to the next parameter. When no parameter setting is required, return the instrument to the SV Setting & Monitor Mode.

6. OPERATION

CAUTIONS

- All mounting and wiring must be completed before the power is turned on. If the input signal wiring is disconnected or short-circuited (RTD input only), the instrument determines that burnout has occurred.
 - Displays:
 - Upscale: Thermocouple input (specify when ordering), RTD input (when input break)
 - Downscale: Thermocouple input (specify when ordering), RTD input (when short-circuited), Voltage input
 - Outputs:
 - Limit output: OFF
 - Alarm action: Both of the Alarm 1 and Alarm 2 actions of this instrument are turned on when burnout occurs regardless of any of the following actions taken (High alarm, low alarm, etc.). In addition, when used for any purposes other than these alarms (event, etc.), set "0000" to the process abnormality action selection (AEo1, AEo2) of "8.7 Function Block 41 (F41), 42 (F42)."
- A power failure of 20 ms or less will not affect the control action. When a power failure of more than 20 ms occurs, the instrument assumes that the power has been turned off. When power returns, the controller will retain the conditions that existed prior to shut down.
- The alarm hold action is activated when not only the power is turned on, but also the SV is changed.

6.1 Operation Procedures

1. Prior to starting operation, check that the mounting and wiring have been finished, and that the limit set value (SV) and various parameters have been set.
2. This instrument does not have a power supply switch.
3. If the power is turned ON, the limit signal continues to be output until the <RST key is pressed regardless of a measured value. First, press the <RST key briefly for one (or more seconds*), then start operation.
 - * Key operation differs depending on the setting in Reset key operation time selection. (P. 9)

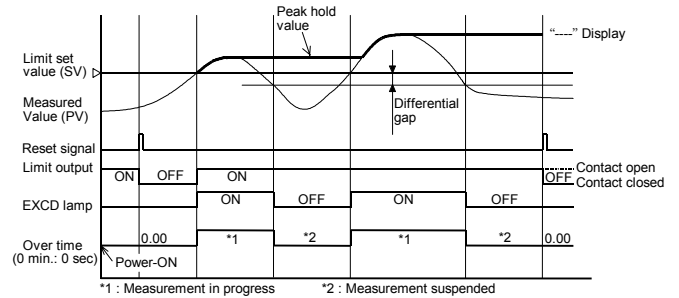

The "peak hold value" and "over time" are reset even when the power is turned OFF.

7. FUNCTIONS

7.1 PV Bias

The value set in the PV bias is added to the input value (actual measured value) to correct the input value. The PV bias is used to correct the individual variations in the sensors or when there is difference between the measured values (PV) of other instruments.

7.2 Digital Filter

This is a software filter which reduces input value variations caused by noise. If the time constant of this filter is set appropriately to match the characteristics of the controlled object and the noise level, the effects of input noise can be suppressed. However, if the time constant is too small, the filter may not be effective, while if the time constant is too large, then the input response may actually deteriorate.

7.3 Set Data Lock (LCK)

The set data lock function permits locking of critical parameters and prevents unauthorized personnel from changing parameters.

7.4 Alarms



Both of the Alarm 1 and Alarm 2 outputs of this instrument are turned on when burnout occurs regardless of any of the following actions taken (High alarm, low alarm, etc.). In addition, when used for any purposes other than these alarms (event, etc.), set "0000" to the process abnormality action selection (AEo1, AEo2) of "8.7 Function Block 41 (F41), 42 (F42)."

Each alarm action is shown below.

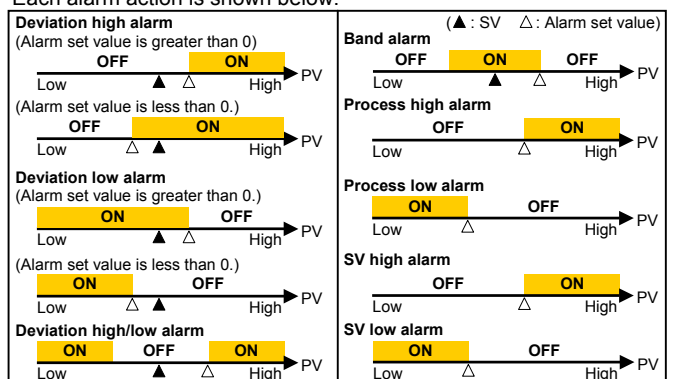

8. INITIAL SETTING



WARNING

Parameters in the Engineering mode should be set according to the application before setting any parameter related to operation. Once the Parameters in the Engineering mode are set correctly, those parameters are not necessary to be changed for the same application under normal conditions. If they are changed unnecessarily, it may result in malfunction or failure of the instrument. RKC will not bear any responsibility for malfunction or failure as a result of improper changes in the Engineering mode.

8.1 Go to Engineering Mode

- Turn on the power to this controller. The instrument goes to the PV/SV monitor after confirming input type symbol and input range.
- Press the SET key for 2 seconds with the SV Setting & Monitor Mode change the instrument to parameter setting mode.
- Press the SET key until "LCK" (Set Data Lock display) will be displayed.
- The blinking digit indicates which digit can be set. Press <RST key to move to the thousands digit.
- Press the UP key to change 0 to 1.
0000: Engineering Mode locked
1000: Engineering Mode unlocked
- Press the SET key to store the new set value. The display goes to the first parameter in Parameter Setting Mode, and the Engineering Mode is unlocked.
- Press the <RST key for 2 seconds while pressing the SET key to go to the Engineering Mode. Thus, the symbol "F10" for function block is displayed first.



Set data lock function display



Alarm 1 setting display



Function block F10 display Engineering mode

8.2 Engineering Menu

Display flowcharts in engineering mode are shown in the following.



Do not change to the section parameters and any parameter in the engineering mode which is not described in the engineering menu below. It may result in malfunction or failure of the instrument.

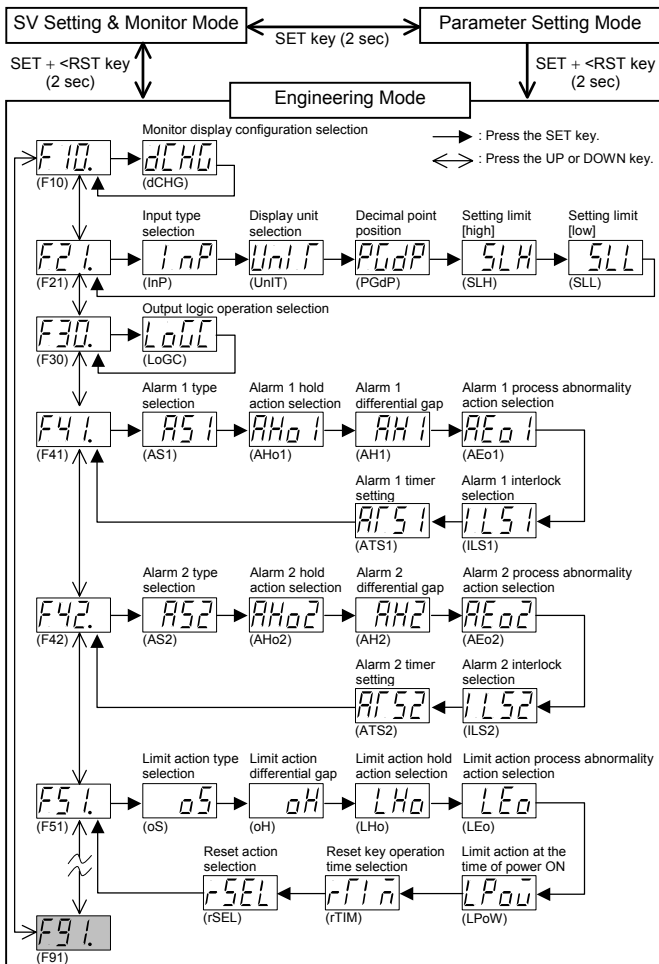

8.3 Attention Items in Setting

If any of the following parameter is changed, the relevant set value is initialized or is automatically converted.



Before changing the set values, always record all of them (SV setting & monitor mode, parameter setting mode and engineering mode).



After changing the set values, always check all of them (SV setting & monitor mode, parameter setting mode and engineering mode).

■ When the input type or engineering unit is changed

The set value is initialized.

Mode	Description	Default value	
		Temperature input	Voltage input
Engineering Mode	Decimal point position	0 (Without decimal point)	1
	Setting limiter [high]	Maximum settable value	100.0
	Setting limiter [low]	Minimum settable value	0.0
	Alarm 1 hold action selection	0 (Without alarm hold action)	
	Alarm 1 differential gap	2 (2.0) °C [°F]	0.2 % of span
	Alarm 1 process abnormality action	Alarm 1 not provided: 0 (Normal) Alarm 1 provided: 1 (Forcibly turned on)	
	Limit action differential gap	2 (2.0) °C [°F]	0.2 % of span
	Alarm 2 hold action selection	0 (Without alarm hold action)	
	Alarm 2 differential gap	2 (2.0) °C [°F]	0.2 % of span
	Alarm 2 process abnormality action	Alarm 1 not provided: 0 (Normal) Alarm 1 provided: 1 (Forcibly turned on)	
Parameter Setting Mode	Alarm 1 set value	50 (50.0) °C [°F]	5.0 % of span
	Alarm 2 set value	50 (50.0) °C [°F]	5.0 % of span
	PV bias	0 (0.0) °C [°F]	0.0
	PV ratio	1.000	
	Digital filter	0 second (OFF)	
	Analog output scale high	Maximum settable value	100.0
SV Setting & Monitor Mode	Analog output scale low	Minimum settable value	0.0
	Limit set value	0 (0.0)	0.0

■ When the position of the decimal point is changed

When change a decimal point position, it is converted into about set value of a list shown below automatically. Set it in value to use once again.

Mode	Description
Engineering Mode	Setting limiter [high limit]
	Setting limiter [low limit]
	Alarm 1 differential gap
	Alarm 2 differential gap
	Limit action differential gap
Parameter Setting Mode	Alarm 1 set value
	Alarm 2 set value
	Analog output scale high
	Analog output scale low
SV Setting & Monitor Mode	Limit set value (SV)



Example and caution of automatic conversion

- Decimal point location moves in accordance with it when increases decimal point location.

Example: When the position of the decimal point changed from 0 to 1 with SLH set to 800 °C.

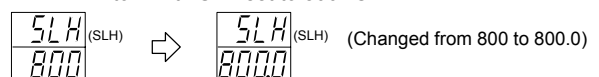

Continued on the next page.

Continued from the previous page.

- If the setting range is not between -1999 and +9999 regardless of the position of the decimal point, it is limited by the range from -1999 to +9999.

Example: Suppose set SLH is 1372 °C, if change decimal point position from 0 to 1.

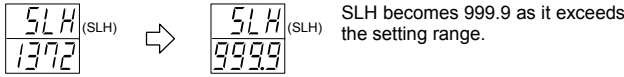

- If the number of digits below the decimal point is changed in the decreasing direction, the decreased number of digits is omitted.

Example: Suppose set SLH is 99.99, if change decimal point position from 0 to 2.

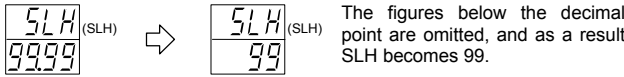

■ When the setting limiter is changed

When change setting limiter [high limit/low limit], all the set value of a list shown below is initialized. Set it in value to use one again.

Mode	Description
Engineering mode	Alarm 1 differential gap
	Alarm 2 differential gap
	Limit action differential gap
Parameter setting mode	Alarm 1 set value
	Alarm 2 set value
	PV bias
	Analog output scale high
	Analog output scale low
SV setting & monitor mode	Limit set value (SV)

<Only for temperature input>

- If SLH is set to SLH<SLL, it is changed to SLH=SLL.
Example: If SLL is set to 200 with SLH set to 100, SLH is changed to 200.
- If SLL is set to SLH<SLL, it is changed to SLH=SLL.
Example: If SLH is set to 100 with SLL set to 200, SLL is changed to 100.

<For temperature input, voltage input>

If the setting is made so that the span becomes narrower, there may be a case where the related set value becomes smaller or 0.

■ When the type of alarm is changed

When change alarm 1 type and alarm 2 type, all the set value of a list shown below is initialized. Set it in value to use one again.

Mode	Description	Default value	
		Temperature input	Voltage input
Engineering mode	Alarm 1 hold action selection	0 (Without alarm hold action)	
	Alarm 1 differential gap	2 (2.0) °C [°F]	0.2 % of span
	Alarm 1 process abnormality action	Alarm 1 not provided: 0 (Normal)	
		Alarm 1 provided: 1 (Forcibly turned on)	
	Alarm 2 hold action selection	0 (Without alarm hold action)	
	Alarm 2 differential gap	2 (2.0) °C [°F]	0.2 % of span
Parameter setting mode	Alarm 1 set value	50 (50.0) °C [°F]	5.0 % of span
	Alarm 2 set value		

8.4 Function Block 10 (F10)

■ Monitor display configuration selection (dCHG)

Factory set value: 0000

Set value	Description	Set value	Description
0000	PV/SV display	0002	Only SV display
0001	Only PV display		—

Displays becomes as follows.

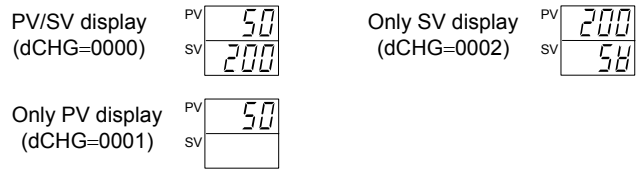

● Change settings

Example: Change the monitor display configuration selection from “PV/SV display” to “Only PV display.”

1. Change the instrument to the function block symbol display “F10.”
 See 8.1 Go to Engineering Mode (P. 6).
2. Press the SET key at “F10” until “dCHG (Monitor display configuration selection)” is displayed.
3. Press the UP key to change the number to 1.
4. Press the SET key to store the new set value. The display goes to the next parameter.

8.5 Function Block 21 (F21)

(1) Input type selection (InP)

Input type (TC/RTD to voltage input or voltage input to TC/RTD) cannot be changed because the hardware is different.

Factory set value varies depending on the instrument specification.

Set value	Description	Set value	Description	
0000	TC	0009	PLII	
0001		0010		U
0002		0011		L
0003		0012	RTD	Pt100
0004		0013		JPt100
0005		0014	Voltage	0 to 5 V DC
0006		0015		1 to 5 V DC
0007		0016		0 to 10 V DC
0008	W5Re/W26Re		—	

● Change settings

Example: Change the input type from “K” to “J”

1. Change the instrument to the function block symbol display.
 See 8.1 Go to Engineering Mode (P. 6).
As “InP” belongs to the “F21,” press the UP key to change the display from “F10” to “F21.”
2. Press the SET key to change to “InP.” Then, press the UP key to enter 1 in the units digit of the set value (SV) display.
3. Press the SET key to store the new set value. The display goes to the next parameter.

(2) Display unit selection (UnIT)

The invalidity in case of the voltage input.

See 8.3 Attention Items in Setting (P. 6).

Factory set value varies depending on the instrument specification.

Set value	Description	Set value	Description
0000	°C	0001	°F

● Change settings

Example: Change the temperature unit of the Heat only type from “°C (0000)” to “°F (0001)”

1. Press the SET key several times at “F21” until “UnIT” is displayed.
2. Press the UP key to change the number to 1.
3. Press the SET key to store the new set value. The display goes to the next parameter.

(3) Decimal point position (PGdP)

Factory set value varies depending on the instrument specification.

Set value	Description
0000	No decimal place (□□□□)
0001	One decimal place (□□□.□)
0002	Two decimal places (□□.□□)
0003	Three decimal places (□.□□□)

Continued on the next page.

● Change settings

Example: Change the decimal point position from “One decimal place (0001)” to “No decimal place (0000)”

1. Press the SET key several times at “F21” until “PGdP” is displayed.
2. Press the DOWN key to change the number to 0.
3. Press the SET key to store the new set value. The display goes to the next parameter.

(4) Setting limiter [high] (SLH) Setting limiter [low] (SLL)

Set the setting limiter referring to the Input Range Table (P. 10).

See 8.3 Attention Items in Setting (P. 6).

Factory set value varies depending on the instrument specification.

Set value	Description	
TC	K	-199 to +1372 °C (-326 to +2502 °F)
		-1999.9 to +999.9 °C (-199.9 to +999.9 °F)
	J	-199 to +1200 °C (-326 to +2192 °F)
		-199.9 to +999.9 °C (-199.9 to +999.9 °F)
	R	0 to 1769 °C (0 to 3216 °F)
	S	0 to 1769 °C (0 to 3216 °F)
	B	0 to 1820 °C (0 to 3308 °F)
	E	0 to 1000 °C (0 to 1832 °F)
	N	0 to 1300 °C (0 to 2372 °F)
		0.0 to 999.9 °C (0 to 999.9 °F)
	T	-199 to +400 °C (-326 to +752 °F)
		-199.9 to +400.0 °C (-199.9 to +752.0 °F)
	W5Re/W26Re	0 to 2320 °C (0 to 4208 °F)
	PL II	0 to 1390 °C (0 to 2534 °F)
U	-199 to +600 °C (-326 to +1112 °F)	
	-199.9 to +600.0 °C (-199.9 to +999.9 °F)	
L	0 to 900 °C (0 to 1652 °F)	
RTD	Pt100 (JIS/IEC) ¹	-199.9 to +649.0 °C (-199.9 to +999.9 °F)
	JPt100 (JIS)	
Voltage ²	0 to 5 V DC	
	1 to 5 V DC	-1999 to +9999 (programmable scale)
	0 to 10 V DC	

¹ IEC (International Electrotechnical Commission) is equivalent to JIS, DIN and ANSI.

² In case of voltage input, SLH can be set below SLL.

● Change settings

Example: When the display range is scaled to 0.0 to 400.0 for a voltage input of 1 to 5 V DC.

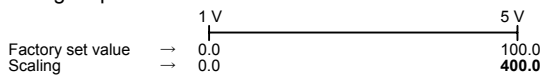

1. Set “F21,” and press the SET key. The display will go to SLH.
2. The blinking digit indicates which digit can be set. Press the <RST key to move to the thousands digit.
3. Press the UP key to change the number to 4.
4. Press the SET key to store the new set value. The display goes to SLL. For the “SLL (Setting limiter [low]),” check that the display is set to “0.0.”

8.6 Function Block 30 (F30)

■ Output logic operation selection (LoGC)

Match the setting with the instrument specification. Otherwise malfunction may result.

Factory set value varies depending on the instrument specification.

Set value	OUT1	OUT2
0001	Limit output (De-energized) *	OR output of alarm 1 and alarm 2 (Energized) *
0002	Limit output (De-energized)	AND output of alarm 1 and alarm 2 (Energized)
0003	Limit output (De-energized)	Alarm 1 output (Energized)
0004	Limit output (De-energized)	OR output of alarm 1 and alarm 2 (De-energized)
0005	Limit output (De-energized)	AND output of alarm 1 and alarm 2 (De-energized)



Set value	OUT1	OUT2
0006	Limit output (De-energized)	Alarm 1 output (De-energized)
0007	Limit output (De-energized)	No output
0008	Limit output (Energized)	OR output of alarm 1 and alarm 2 (Energized)
0009	Limit output (Energized)	AND output of alarm 1 and alarm 2 (Energized)
0010	Limit output (Energized)	Alarm 1 output (Energized)
0011	Limit output (Energized)	OR output of alarm 1 and alarm 2 (De-energized)
0012	Limit output (Energized)	AND output of alarm 1 and alarm 2 (De-energized)
0013	Limit output (Energized)	Alarm 1 output (De-energized)
0014	Limit output (Energized)	No output
0015	Transmission output *	Limit output (De-energized) *
0016	Transmission output	Limit output (Energized)

* Standard output when no output code is specified.

When the OUT1 is relay contact output: 0001

When the OUT1 is current output: 0015

8.7 Function Block 41 (F41), 42 (F42)

(1) Alarm 1 type selection (AS1)

Alarm 2 type selection (AS2)

See 8.3 Attention Items in Setting (P. 6).

Factory set value varies depending on the instrument specification.

Set value	Description	Set value	Description
0000	Alarm not provided	0005	Deviation high alarm
0001	SV high alarm	0006	Deviation low alarm
0002	SV low alarm	0007	Deviation high/low alarm
0003	Process high alarm	0008	Band alarm
0004	Process low alarm		—

● Change settings

Example: Change the Alarm 1 type from “Deviation high alarm (0005)” to “Deviation low alarm (0006)”

1. Press the SET key at “F41” until “AS1” is displayed.
2. Press the UP key to change the number to 6.
3. Press the SET key to store the new set value. The display goes to the next parameter.

(2) Alarm 1 hold action selection (AHO1)

Alarm 2 hold action selection (AHO2)



The alarm hold action function can not be added to the SV alarm.

See 8.3 Attention Items in Setting (P. 6).

Factory set value varies depending on the instrument specification.

Set value	Description
0000	Without alarm hold action
0001	Effective when the power is turned on.
0002	Effective when the power is turned on or the SV is changed.

● Change settings

Example: Change the Alarm 1 hold action selection from “Without alarm hold action (0000)” to “Effective when the power is turned on (0001)”

1. Press the SET key at “F41” until “AHO1” is displayed.
2. Press the UP key to change the number to 1.
3. Press the SET key to store the new set value. The display goes to the next parameter.

(3) Alarm 1 differential gap (AH1)

Alarm 2 differential gap (AH2)

Setting range: 0 (0.0) to span

Factory set value: TC and RTD inputs: 2 (2.0) °C [°F]

Voltage input: 0.2 % of span

● Change settings

Example: Change the Alarm 1 differential gap from “2 °C” to “4 °C”

1. Press the SET key at “F41” until “AH1” is displayed.
2. Press the UP key to change the number to 4.
3. Press the SET key to store the new set value. The display goes to the next parameter.

**(4) Alarm 1 process abnormality action selection (AEo1)
Alarm 2 process abnormality action selection (AEo2)**

 It is judged that the input is abnormal when over-scale or underscale occurs.

 For a voltage input of 0 to 5 V DC or 0 to 10 V DC, as over-scale or underscale does not occur when the input breaks, no alarm is turned on.

Set value	Description
0000	Normal processing: The alarm action set by alarm type selection (AS1/AS2) is taken even if the input is abnormal.
0001	Forcibly turned on when abnormal: The alarm is forcibly turned on regardless of the alarm action set by alarm type selection (AS1/AS2) when the input is abnormal.

Factory set value:

Alarm 1 not provided: 0000, Alarm 1 provided: 0001
Alarm 2 not provided: 0000, Alarm 2 provided: 0001

● Change settings

Example: Change the Alarm 1 process abnormality action selection from "Normal processing (0000)" to "Forcibly turned on when abnormal (0001)"

1. Press the SET key at "F41" until "AEo1" is displayed.
2. Press the UP key to change the number to 1.
3. Press the SET key to store the new set value. The display goes to the next parameter.

**(5) Alarm 1 interlock selection (ILS1)
Alarm 2 interlock selection (ILS2)**

Factory set value: 0000

Set value	Description
0000	Without alarm interlock
0001	With alarm interlock

● Change settings

Example: Change the Alarm 1 interlock selection from "Without alarm interlock (0000)" to "With alarm interlock (0001)"

1. Press the SET key at "F41" until "ILS1" is displayed.
2. Press the UP key to change the number to 1.
3. Press the SET key to store the new set value. The display goes to the next parameter.

**(6) Alarm 1 timer setting (ATS1)
Alarm 2 timer setting (ATS2)**

Setting range: 0 to 60 seconds
Factory set value: 0

● Change settings

Example: Change the Alarm 1 timer setting from "0 second" to "30 seconds"

1. Press the SET key at "F41" until "ATS1" is displayed.
2. The blinking digit indicates which digit can be set. Press the <RST key to move to the tens digit.
3. Press the UP key to change the number to 3.
4. Press the SET key to store the new set value. The display goes to the next parameter.

8.8 Function Block 51 (F51)

(1) Limit action type selection (oS)

Factory set value: 0000

Set value	Description
0000	Limit action [high limit]
0001	Limit action [low limit]

● Change settings

Example: Change the Limit action type from "Limit action [high limit] (0000)" to "Limit action [low limit] (0001)"

1. Press the SET key at "F51" until "oS" is displayed.
2. Press the UP key to change the number to 1.
3. Press the SET key to store the new set value. The display goes to the next parameter.

(2) Limit action differential gap (oH)

Setting range: 0 (0.0) to span
Factory set value: TC and RTD inputs: 2 (2.0) °C [°F]
Voltage input: 0.2 % of span

 The setting procedure is the same as the Alarm differential gap. (P. 8)

(3) Limit action hold action selection (LHo)

Factory set value: 0000

Set value	Description
0000	Without hold action
0001	Effective when the power is turned on.

 The setting procedure is the same as the (1) Limit action type selection. (P. 9)

(4) Limit action process abnormality action selection (LEo)

Factory set value: 0000

Set value	Description
0000	Normal processing
0001	Forcibly turned on when abnormal

 The setting procedure is the same as the (1) Limit action type selection. (P. 9)

(5) Limit action at the time of power ON (LPoW)

Factory set value: 0001

Set value	Description
0000	Limit action output turned OFF at the time of power ON.
0001	Limit action output turned ON at the time of power ON.

 The setting procedure is the same as the (1) Limit action type selection. (P. 9)

(6) <RST key operation time selection (rTIM)

Factory set value: 0001

Set value	Description
0000	Press for one second.
0001	Press once.

 The setting procedure is the same as the (1) Limit action type selection. (P. 9)

(7) Reset action selection (rSEL)

Factory set value: 0000

Set value	Description
0000	All data is reset with each monitoring screen.
0001	Each data is reset with each monitoring screen.

 The setting procedure is the same as the (1) Limit action type selection. (P. 9)

8.9 Exit Engineering Mode

1. Transfer to function block symbol display (F□□) after each parameter is set.
2. Press the <RST key while pressing the SET key for 2 seconds to change to the SV Setting & Monitor Mode from the Engineering Mode.
3. Press the SET key for 2 seconds with the SV Setting & Monitor Mode change the instrument to Parameter Setting Mode.
4. Press the SET key to change to the set data lock function display (LCK).
5. Press the <RST key to flash the most significant digit on the set value (SV) display.
6. Press the DOWN key to change 1 to 0 in the most significant digit.
7. Press the SET key to lock the Engineering Mode. The display changes to the first parameter in Parameter Setting Mode.
8. Press the SET key for 2 seconds to change the Parameter Setting Mode to the SV Setting & Monitor Mode. Thus, the initialization ends.

9. ERROR DISPLAYS

Self-diagnostic error

Upper display	Lower display	Description	Solution
Err	1	Adjusted data error	Turn off the power once. If an error occurs after the power is turned on again, please contact RKC sales office or the agent.
	2	EEPROM error	
	4	A/D conversion error	
	8	RAM check error	
	128	Watchdog timer error	
	2048 4096	Program busy	



When two or more errors occur simultaneously, the error code numbers are totaled and displayed as one number.

Overscale and Underscale

Upper display	Description	Solution
Measured value (PV) is flashing	PV is outside of input range.	WARNING To prevent electric shock, always turn off the power before replacing the sensor.
	Overscale: PV is above the high input display range limit.	
	Underscale: PV is below the low input display range limit.	
		Check the sensor or input lead.

10. SPECIFICATIONS

Input

Thermocouple: K, J, R, S, B, E, T, N (JIS-C1602-1995)
PLII (NBS)
W5Re/W26Re (ASTM-E988-96)
U, L (DIN43710-1985)

RTD: Pt100 (JIS-C1604-1997)
JPt100 (JIS-C1604-1997, JIS-C1604-1981 Pt100)
Voltage: 0 to 5 V DC, 1 to 5 V DC, 0 to 10 V DC

Display accuracy

Thermocouple: $\pm(1\% \text{ of displayed value} + 1 \text{ digit})$ or $\pm 2\text{ }^\circ\text{C}$ [$^\circ\text{F}$]
RTD: $\pm(0.3\% \text{ of displayed value} + 1 \text{ digit})$ or $\pm 0.8\text{ }^\circ\text{C}$ [$^\circ\text{F}$]
Voltage: $\pm(0.3\% \text{ of span} + 1 \text{ digit})$

Output (OUT1, OUT2)

Relay contact: 240 V AC, 3A (Resistive load) 1c contact,
Electric life 300,000 times or more (Rated load)

Current: 0 to 20 mA DC, 4 to 20 mA DC
(OUT1 only) (Load resistance: 400 Ω or less,
Resolution: 10 bits or more)

Communication function (Option)

Interface: Based on RS-485, EIA standard
Protocol: RKC communication, Modbus

Contact input (Option)

Dry contact input: At open 500 k Ω or more, At close 10 Ω or less

Power supply voltage

100 to 240 V AC:

85 to 264 V AC (50/60 Hz) [Power supply voltage range]
Rating: 100 to 240 V AC

24 V AC: 21.6 to 26.4 V AC (50/60 Hz) [Power supply voltage range]
Rating: 24 V AC

24 V DC: 21.6 to 26.4 V AC (50/60 Hz) [Power supply voltage range]
Rating: 24 V DC

Power consumption

100 to 240 V AC: 4 VA max. (at 100 V AC), 7 VA max. (at 240 V AC)

24 V AC: 4 VA max.

24 V DC: 100 mA max.



Standards

Safety standards: UL: UL3101-1
CSA: CAN/CSA-C22.2 No. 1010.1
FM: Class Number 3545 (in application)
CE marking: LVD: EN61010-1
EMC: EN55011, EN61000-3-2, EN61326

Others

Dimension: 48 × 48 × 70 mm (W × H × D)
Weight: Approx. 120 g

11. INPUT RANGE TABLES

TC/RTD

Input type	Input range	Code	Input type	Input range	Code
K	0 to 200 $^\circ\text{C}$	01	TC	-199.9 to +400.0 $^\circ\text{C}$ ²	01
	0 to 400 $^\circ\text{C}$	02		-199.9 to +100.0 $^\circ\text{C}$ ²	02
	0 to 600 $^\circ\text{C}$	03		-100.0 to +200.0 $^\circ\text{C}$	03
	0 to 800 $^\circ\text{C}$	04		0.0 to 350.0 $^\circ\text{C}$	04
	0 to 1000 $^\circ\text{C}$	05		-199.9 to +752.0 $^\circ\text{F}$ ²	T A1
	0 to 1200 $^\circ\text{C}$	06		-100.0 to +200.0 $^\circ\text{F}$	A2
	0 to 1372 $^\circ\text{C}$	07		-100.0 to +400.0 $^\circ\text{F}$	A3
	-199.9 to +300.0 $^\circ\text{C}$	08		0.0 to 450.0 $^\circ\text{F}$	A4
	0.0 to 400.0 $^\circ\text{C}$	09		0.0 to 752.0 $^\circ\text{F}$	A5
	0.0 to 800.0 $^\circ\text{C}$	10		0.0 to 2000 $^\circ\text{C}$	01
	0 to 100 $^\circ\text{C}$	13		0 to 2320 $^\circ\text{C}$	W A1
	0 to 300 $^\circ\text{C}$	14		0 to 4000 $^\circ\text{F}$	A1
	0 to 450 $^\circ\text{C}$	17		0 to 1300 $^\circ\text{C}$	01
	0 to 500 $^\circ\text{C}$	20		0 to 1390 $^\circ\text{C}$	02
0.0 to 200.0 $^\circ\text{C}$	29	0 to 1200 $^\circ\text{C}$	A 03		
0.0 to 600.0 $^\circ\text{C}$	37	0 to 2400 $^\circ\text{F}$	A1		
-199.9 to +800.0 $^\circ\text{C}$	38	0 to 2534 $^\circ\text{F}$	A2		
0 to 800 $^\circ\text{F}$	A1	-199.9 to +600.0 $^\circ\text{C}$ ²	01		
0 to 1600 $^\circ\text{F}$	A2	-199.9 to +100.0 $^\circ\text{C}$ ²	02		
0 to 2502 $^\circ\text{F}$	A3	0.0 to 400.0 $^\circ\text{C}$	03		
0.0 to 800.0 $^\circ\text{F}$	A4	-199.9 to +999.9 $^\circ\text{F}$ ²	U A1		
20 to 70 $^\circ\text{F}$	A9	-100.0 to +200.0 $^\circ\text{F}$	A2		
-199.9 to +999.9 $^\circ\text{F}$	B2	0.0 to 999.9 $^\circ\text{F}$	A3		
0 to 200 $^\circ\text{C}$	01	0 to 400 $^\circ\text{C}$	01		
0 to 400 $^\circ\text{C}$	02	0 to 800 $^\circ\text{C}$	A 02		
0 to 600 $^\circ\text{C}$	03	0 to 800 $^\circ\text{F}$	L A1		
0 to 800 $^\circ\text{C}$	04	0 to 1600 $^\circ\text{F}$	A2		
0 to 1000 $^\circ\text{C}$	05	-199.9 to +649.0 $^\circ\text{C}$	01		
0 to 1200 $^\circ\text{C}$	06	-199.9 to +200.0 $^\circ\text{C}$	02		
-199.9 to +300.0 $^\circ\text{C}$	07	-100.0 to +50.0 $^\circ\text{C}$	03		
0.0 to 400.0 $^\circ\text{C}$	08	-100.0 to +100.0 $^\circ\text{C}$	04		
0.0 to 800.0 $^\circ\text{C}$	09	-100.0 to +200.0 $^\circ\text{C}$	05		
0 to 450 $^\circ\text{C}$	10	0.0 to 50.0 $^\circ\text{C}$	06		
0.0 to 200.0 $^\circ\text{C}$	22	0.0 to 100.0 $^\circ\text{C}$	07		
0.0 to 600.0 $^\circ\text{C}$	23	0.0 to 200.0 $^\circ\text{C}$	08		
-199.9 to +600.0 $^\circ\text{C}$	30	0.0 to 300.0 $^\circ\text{C}$	09		
0 to 800 $^\circ\text{F}$	A1	0.0 to 500.0 $^\circ\text{C}$	D 10		
0 to 1600 $^\circ\text{F}$	A2	-199.9 to +999.9 $^\circ\text{F}$	A1		
0 to 2192 $^\circ\text{F}$	A3	-199.9 to +400.0 $^\circ\text{F}$	A2		
0 to 400 $^\circ\text{F}$	A6	-199.9 to +200.0 $^\circ\text{F}$	A3		
-199.9 to +999.9 $^\circ\text{F}$	A9	-199.9 to +100.0 $^\circ\text{F}$	A4		
0 to 800.0 $^\circ\text{F}$	B6	-199.9 to +300.0 $^\circ\text{F}$	A5		
0 to 1600 $^\circ\text{C}$ ¹	01	0.0 to 100.0 $^\circ\text{F}$	A6		
0 to 1769 $^\circ\text{C}$ ¹	02	0.0 to 200.0 $^\circ\text{F}$	A7		
0 to 1350 $^\circ\text{C}$ ¹	04	0.0 to 400.0 $^\circ\text{F}$	A8		
0 to 3200 $^\circ\text{F}$ ¹	A1	0.0 to 500.0 $^\circ\text{F}$	A9		
0 to 3216 $^\circ\text{F}$ ¹	A2	-199.9 to +649.0 $^\circ\text{C}$	01		
0 to 1600 $^\circ\text{C}$ ¹	01	-199.9 to +200.0 $^\circ\text{C}$	02		
0 to 1769 $^\circ\text{C}$ ¹	02	-100.0 to +50.0 $^\circ\text{C}$	03		
0 to 3200 $^\circ\text{F}$ ¹	A1	-100.0 to +100.0 $^\circ\text{C}$	04		
0 to 3216 $^\circ\text{F}$ ¹	A2	-100.0 to +200.0 $^\circ\text{C}$	05		
400 to 1800 $^\circ\text{C}$	01	0.0 to 50.0 $^\circ\text{C}$	P 06		
0 to 1820 $^\circ\text{C}$ ¹	02	0.0 to 100.0 $^\circ\text{C}$	07		
800 to 3200 $^\circ\text{F}$	A1	0.0 to 200.0 $^\circ\text{C}$	08		
0 to 3308 $^\circ\text{F}$	A2	0.0 to 300.0 $^\circ\text{C}$	09		
0 to 800 $^\circ\text{C}$	01	0.0 to 500.0 $^\circ\text{C}$	10		
0 to 1000 $^\circ\text{C}$	02				
0 to 1600 $^\circ\text{F}$	A1				
0 to 1832 $^\circ\text{F}$	A2				
0 to 1200 $^\circ\text{C}$	01				
0 to 1300 $^\circ\text{C}$	02				
0.0 to 800.0 $^\circ\text{C}$	06				
0 to 2300 $^\circ\text{F}$	A1				
0 to 2372 $^\circ\text{F}$	A2				
0.0 to 999.9 $^\circ\text{F}$	A5				

¹Accuracy is not guaranteed between 0 to 399 $^\circ\text{C}$ (0 to 751 $^\circ\text{F}$).
²Accuracy is not guaranteed between -199.9 to -100.0 $^\circ\text{C}$ (-199.9 to -148.0 $^\circ\text{F}$).

Voltage/current

Input type	Input range	Code	Input type	Input range	Code
Voltage	0 to 5 V DC	4	Current	0 to 20 mA DC	7
	0 to 10 V DC	5		4 to 20 mA DC	8
	1 to 5 V DC	6			

The first edition: JUL.2004 [IMQ00]